

Name: Kit Setup - Laydown Date: \_\_\_\_\_ Event: \_\_\_\_\_  
 City: \_\_\_\_\_ State: \_\_\_\_\_ Track: \_\_\_\_\_



Track  Indoor  Tight  Smooth  Hard Packed  Blue Groove  Wet  Grass  Low Bite  High Bite  
 Conditions  Outdoor  Open  Rough  Loose/Loamy  Dry  Dusty  Astro Turf  Med Bite  Other \_\_\_\_\_

**Front Suspension**

Toe: +/- 0 deg  
 Ride Height: 28mm Camber: -1 deg  
 Caster: 0° 5°  
 Kick Angle: 20° 25° 30°  
 VLA Setting: Short Arm Long Arm  
 Front Pivot: Alum Plastic HRC Alum HRC  
 Kick Shim: Brass Plastic  
 Oil: 32.5 wt  
 Piston: 2 x 1.6mm (TLR233009)  
 Spring: Standard Low Freq. Color: Blue  
 Sway Bar: 0.8mm 1.0mm 1.2mm   
 Shock Limiters: 1mm Stroke: 28mm  
 Shock Locations: 2 - Middle  
 Spindle Ball Stud: Standard Low Mount  
 Bump Steer Spacers: 0mm  
 Ackerman Ball Stud: Standard Low Mount  
 Ackerman Spacers: 1mm  
 Ackerman Arm: #1 #2 #3   
 Trail: 2mm 3mm 4mm  
 Camber Link: 1 - A

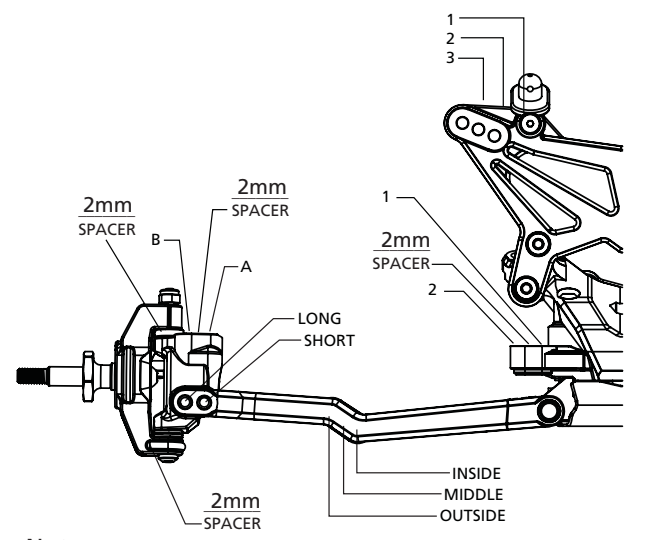

Notes: \_\_\_\_\_  
 \_\_\_\_\_  
 \_\_\_\_\_

**Rear Suspension**

Configuration: Laydown Standup  
 LD Diff. Height: Standard +3.5mm  
 Transmission Type: 3-Gear 4-Gear  
 Toe Inserts: 0.5 1 1.5 2 2.5 3 3.5 4  
 Anti-Squat Inserts: 0 0.5 1 1.5 2 2.5 3  
 Inner Roll Center: LRC HRC  
 Ride Height: 28mm Camber: -1 deg  
 Rear Hub Spacing: Middle  
 Rear Axle Height: Standard +3mm  
 Hex Width: SCT Standard  
 Sway Bar: 1.0mm 1.2mm 1.4mm   
 Oil: 32.5 wt  
 Piston: 2 x 1.7mm (TLR233010)  
 Spring: Standard Low Freq. Color: Yellow  
 Shock Limiters: 2mm Stroke: 33mm  
 Shock Locations: 2 - Inside  
 Shock Mounting: Front Rear  
 Inner Link Spacer: -1mm 0mm +1mm  
 Camber Link: 2 - B  
 Battery Position: \_\_\_\_\_  
 Diff Type: Ball Gear Setting: \_\_\_\_\_  
 Driveshaft Length: CVA Universal Length: \_\_\_\_\_

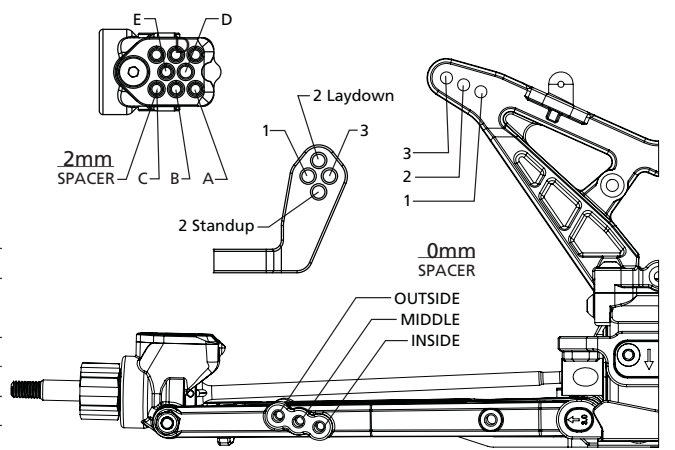

**Electronics**

Radio: \_\_\_\_\_ Timing Advance: \_\_\_\_\_  
 Servo: \_\_\_\_\_ Throttle/Brake Expo: \_\_\_\_\_  
 ESC: \_\_\_\_\_ Servo Expo: \_\_\_\_\_  
 Initial Brake: \_\_\_\_\_ Throttle/Brake EPA: \_\_\_\_\_  
 Drag Brake: \_\_\_\_\_ Motor: \_\_\_\_\_  
 Throttle Profile: \_\_\_\_\_ Pinion: \_\_\_\_\_ Spur: 82T  
 Battery: \_\_\_\_\_

**Chassis**

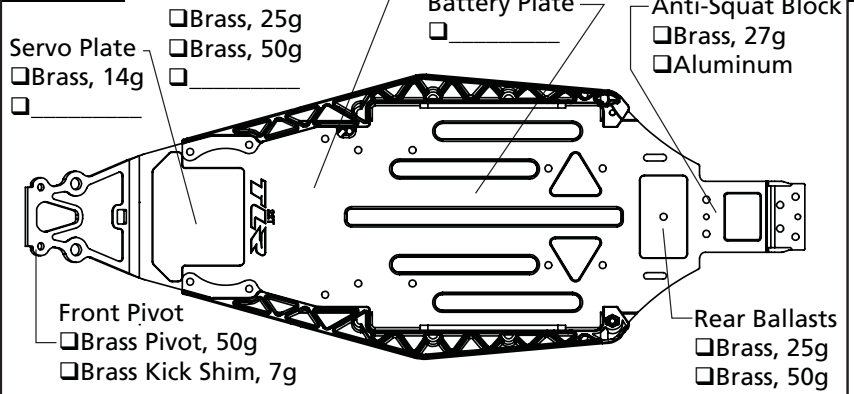

**Tires**

	Front	Rear
Tire:	_____	_____
Compound:	_____	_____
Insert:	_____	_____
Additive:	_____	_____
Notes:	_____	
	_____	

Name: \_\_\_\_\_ Date: \_\_\_\_\_ Event: \_\_\_\_\_  
 City: \_\_\_\_\_ State: \_\_\_\_\_ Track: \_\_\_\_\_



Track Conditions:  Indoor  Tight  Smooth  Hard Packed  Blue Groove  Wet  Grass  Low Bite  High Bite  
 Outdoor  Open  Rough  Loose/Loamy  Dry  Dusty  Astro Turf  Med Bite  Other \_\_\_\_\_

**Front Suspension**

Toe: \_\_\_\_\_  
 Ride Height: \_\_\_\_\_ Camber: \_\_\_\_\_  
 Caster: 0° 5°  
 Kick Angle: 20° 25° 30°  
 VLA Setting: Short Arm Long Arm  
 Front Pivot: Alum Plastic HRC Alum HRC  
 Kick Shim: Brass Plastic  
 Oil: \_\_\_\_\_  
 Piston: \_\_\_\_\_  
 Spring: Standard Low Freq. Color: \_\_\_\_\_  
 Sway Bar: 0.8mm 1.0mm 1.2mm  \_\_\_\_\_  
 Shock Limiters: \_\_\_\_\_ Stroke: \_\_\_\_\_  
 Shock Locations: \_\_\_\_\_  
 Spindle Ball Stud: Standard Low Mount  
 Bump Steer Spacers: \_\_\_\_\_  
 Ackerman Ball Stud: Standard Low Mount  
 Ackerman Spacers: \_\_\_\_\_  
 Ackerman Arm: #1 #2 #3  \_\_\_\_\_  
 Trail: 2mm 3mm 4mm  
 Camber Link: \_\_\_\_\_

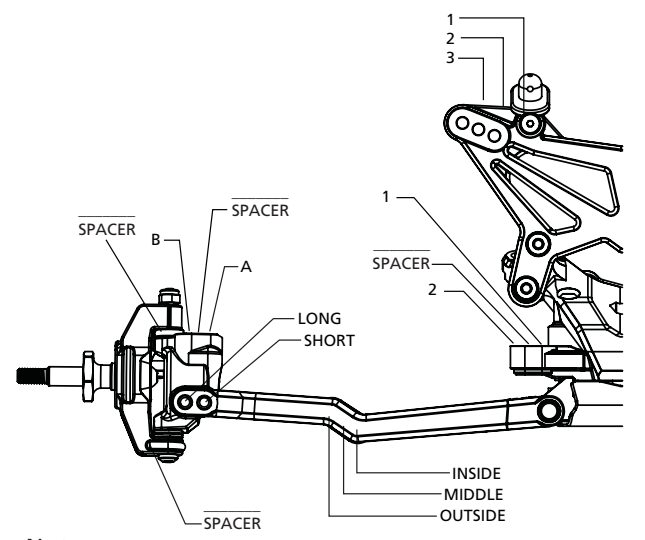

Notes: \_\_\_\_\_  
 \_\_\_\_\_  
 \_\_\_\_\_

**Rear Suspension**

Configuration: Laydown Standup  
 LD Diff. Height: Standard +3.5mm  
 Transmission Type: 3-Gear 4-Gear  
 Toe Inserts: 0.5 1 1.5 2 2.5 3 3.5 4  
 Anti-Squat Inserts: 0 0.5 1 1.5 2 2.5 3  
 Inner Roll Center: LRC HRC  
 Ride Height: \_\_\_\_\_ Camber: \_\_\_\_\_  
 Rear Hub Spacing: \_\_\_\_\_  
 Rear Axle Height: Standard +3mm  
 Hex Width: \_\_\_\_\_  
 Sway Bar: 1.0mm 1.2mm 1.4mm  \_\_\_\_\_  
 Oil: \_\_\_\_\_  
 Piston: \_\_\_\_\_  
 Spring: Standard Low Freq. Color: \_\_\_\_\_  
 Shock Limiters: \_\_\_\_\_ Stroke: \_\_\_\_\_  
 Shock Locations: \_\_\_\_\_  
 Shock Mounting: Front Rear  
 Inner Link Spacer: -1mm 0mm +1mm  
 Camber Link: \_\_\_\_\_  
 Battery Position: \_\_\_\_\_  
 Diff Type: Ball Gear Setting: \_\_\_\_\_  
 Driveshaft Length: CVA Universal Length: \_\_\_\_\_

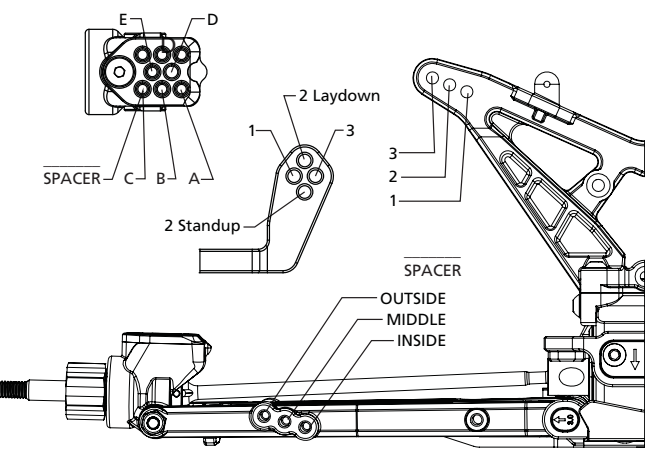

**Electronics**

Radio: \_\_\_\_\_ Timing Advance: \_\_\_\_\_  
 Servo: \_\_\_\_\_ Throttle/Brake Expo: \_\_\_\_\_  
 ESC: \_\_\_\_\_ Servo Expo: \_\_\_\_\_  
 Initial Brake: \_\_\_\_\_ Throttle/Brake EPA: \_\_\_\_\_  
 Drag Brake: \_\_\_\_\_ Motor: \_\_\_\_\_  
 Throttle Profile: \_\_\_\_\_ Pinion: \_\_\_\_\_ Spur: \_\_\_\_\_  
 Battery: \_\_\_\_\_

**Chassis**

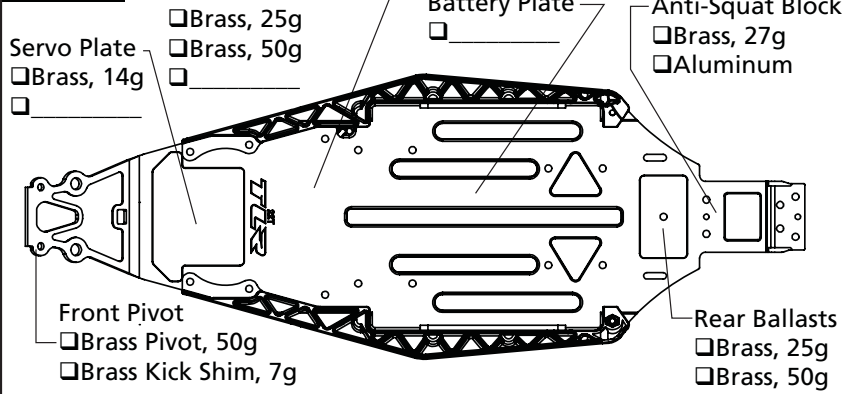

**Tires**

	Front	Rear
Tire:	_____	_____
Compound:	_____	_____
Insert:	_____	_____
Additive:	_____	_____
Notes:	_____	
	_____	

Name: \_\_\_\_\_ Date: \_\_\_\_\_ Event: \_\_\_\_\_  
 City: \_\_\_\_\_ State: \_\_\_\_\_ Track: \_\_\_\_\_



Track Conditions:  Indoor  Tight  Smooth  Hard Packed  Blue Groove  Wet  Grass  Low Bite  High Bite  
 Outdoor  Open  Rough  Loose/Loamy  Dry  Dusty  Astro Turf  Med Bite  Other \_\_\_\_\_

**Front Suspension**

Toe: \_\_\_\_\_  
 Ride Height: \_\_\_\_\_ Camber: \_\_\_\_\_  
 Caster: 0° 5°  
 Kick Angle: 20° 25° 30°  
 VLA Setting: Short Arm Long Arm  
 Front Pivot: Alum Plastic HRC Alum HRC  
 Kick Shim: Brass Plastic  
 Oil: \_\_\_\_\_  
 Piston: \_\_\_\_\_  
 Spring: Standard Low Freq. Color: \_\_\_\_\_  
 Sway Bar: 0.8mm 1.0mm 1.2mm 1.4mm  
 Shock Limiters: \_\_\_\_\_ Stroke: \_\_\_\_\_  
 Shock Locations: \_\_\_\_\_  
 Spindle Ball Stud: Standard Low Mount  
 Bump Steer Spacers: \_\_\_\_\_  
 Ackerman Ball Stud: Standard Low Mount  
 Ackerman Spacers: \_\_\_\_\_  
 Ackerman Arm: #1 #2 #3 #4  
 Trail: 2mm 3mm 4mm  
 Camber Link: \_\_\_\_\_

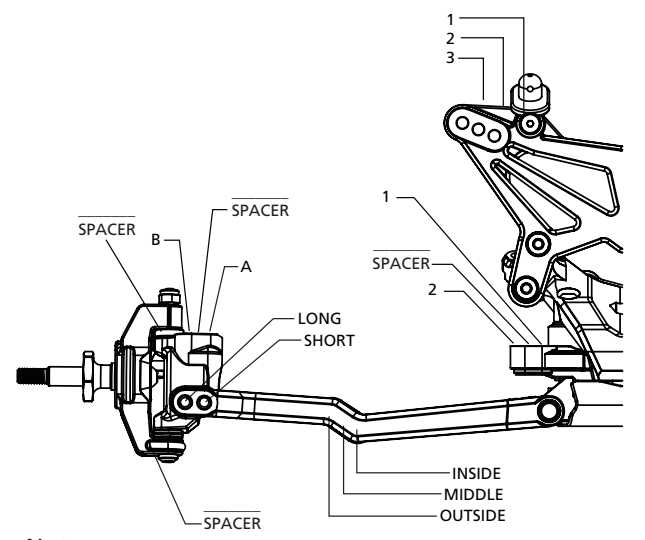

Notes: \_\_\_\_\_  
 \_\_\_\_\_  
 \_\_\_\_\_

**Rear Suspension**

Configuration: Laydown Standup  
 LD Diff. Height: Standard +3.5mm  
 Transmission Type: 3-Gear 4-Gear  
 Toe Inserts: 0.5 1 1.5 2 2.5 3 3.5 4  
 Anti-Squat Inserts: 0 0.5 1 1.5 2 2.5 3  
 Inner Roll Center: LRC HRC  
 Ride Height: \_\_\_\_\_ Camber: \_\_\_\_\_  
 Rear Hub Spacing: \_\_\_\_\_  
 Rear Axle Height: Standard +3mm  
 Hex Width: \_\_\_\_\_  
 Sway Bar: 1.0mm 1.2mm 1.4mm 1.6mm  
 Oil: \_\_\_\_\_  
 Piston: \_\_\_\_\_  
 Spring: Standard Low Freq. Color: \_\_\_\_\_  
 Shock Limiters: \_\_\_\_\_ Stroke: \_\_\_\_\_  
 Shock Locations: \_\_\_\_\_  
 Shock Mounting: Front Rear  
 Inner Link Spacer: -1mm 0mm +1mm  
 Camber Link: \_\_\_\_\_  
 Battery Position: \_\_\_\_\_  
 Diff Type: Ball Gear Setting: \_\_\_\_\_  
 Driveshaft Length: CVA Universal Length: \_\_\_\_\_

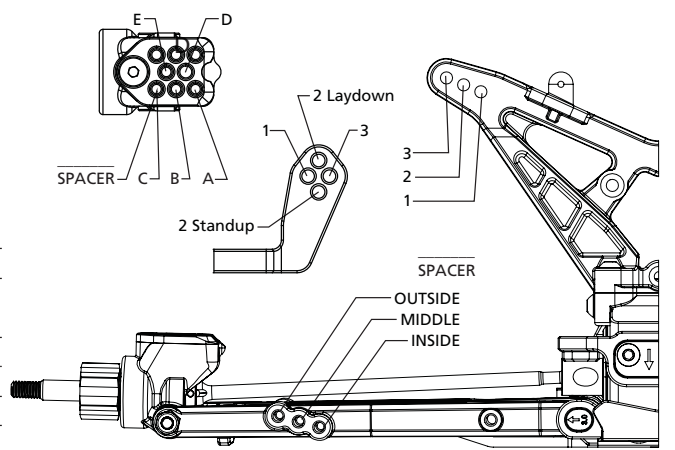

**Electronics**

Radio: \_\_\_\_\_ Timing Advance: \_\_\_\_\_  
 Servo: \_\_\_\_\_ Throttle/Brake Expo: \_\_\_\_\_  
 ESC: \_\_\_\_\_ Servo Expo: \_\_\_\_\_  
 Initial Brake: \_\_\_\_\_ Throttle/Brake EPA: \_\_\_\_\_  
 Drag Brake: \_\_\_\_\_ Motor: \_\_\_\_\_  
 Throttle Profile: \_\_\_\_\_ Pinion: \_\_\_\_\_ Spur: \_\_\_\_\_  
 Battery: \_\_\_\_\_

**Chassis**

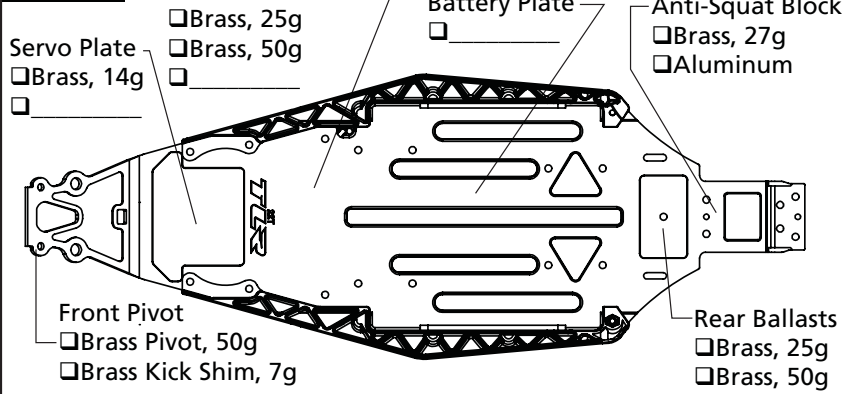

**Tires**

	Front	Rear
Tire:	_____	_____
Compound:	_____	_____
Insert:	_____	_____
Additive:	_____	_____
Notes:	_____	
	_____	